

Skid unit with a piston pump

Vertical polyethylene tank
High pressure

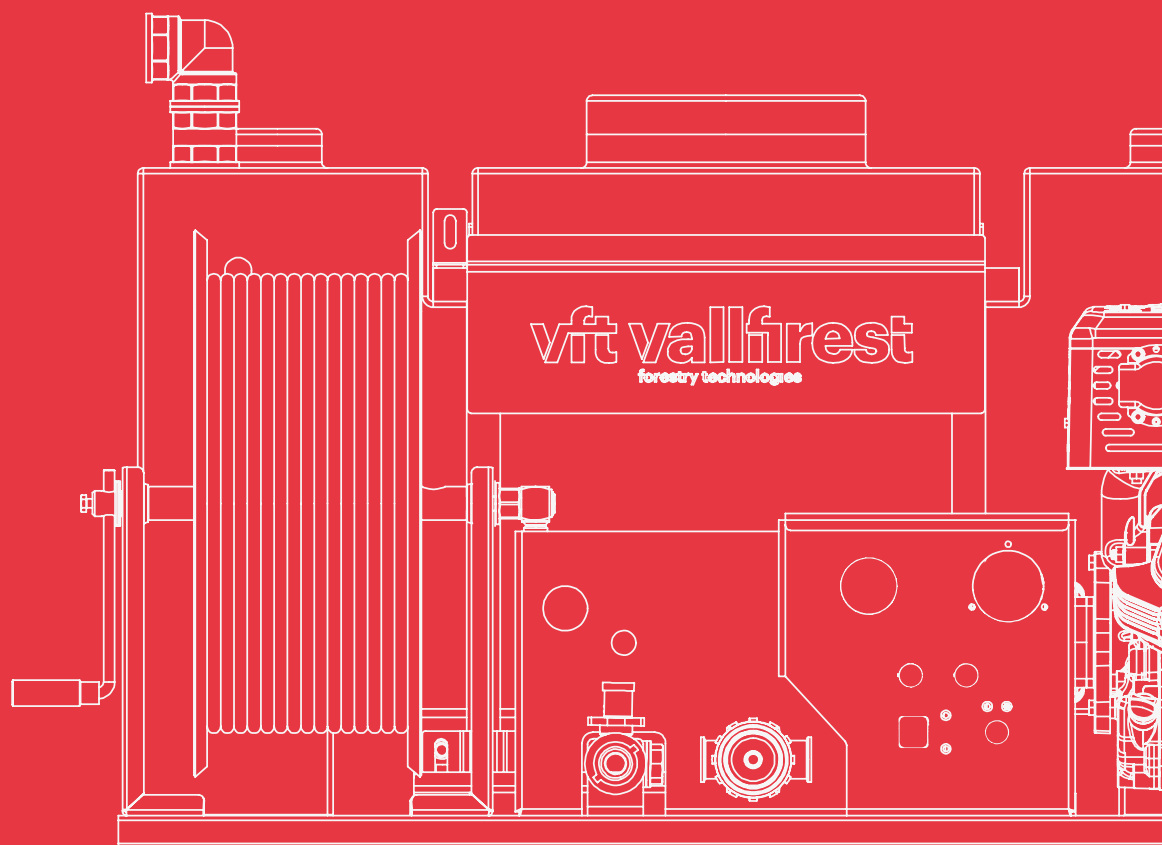

Polyethylene skid unit with a piston pump

High pressure | Up to 200 bar

Rapid intervention skid units designed for pickup vehicles and trailers, equipped with piston pumps up to 200 bar with a maximum flow of up to 42 L/min.

- High-quality components and great replacement part availability
- Resistant tanks made of polyethylene
- The best quality/price ratio
- 2 year warranty



What is included?

Motor	Gasoline 13.5 HP
Piston pump	42 L/min. 100 bar at 21 L/min. 200 bar
Quick attack winder	Equipped with a high-pressure hose
Water tank	400 L
Attack nozzle	Multi-purpose water and foam
Suction oversleeve	5 m long
Foam-forming agent proportioner system	2.5mm injector

Uses

Wildland fires	Less recommended
Container and vehicle fires	Recommended use
Cleaning and unclogging	Recommended use

1 Motor pump unit

Available options. 4-stroke gasoline combustion motors and 3-piston high-pressure volumetric pumps.



Motors	Power *	Pump	Max. pressure **	Max. flow **
B&S XR2100	13.5 HP	XWL 42.10 N	100 bar	42 l/min
B&S XR2100	13.5 HP	XW 21.20 N	200 bar	21 l/min

Gasoline motor.

* The nominal engine power indicated in this document is the net power tested on a production engine for the engine model pursuant to SAE J1940 (Briggs & Stratton) at a specific speed. This value may vary in mass produced motors. The actual output power of the engine installed on the end machine will vary depending on a number of factors such as the applicable engine operating speed, the environmental conditions, maintenance and other variables.

** These values are at direct pump outlet.

*** The power, pressure and flow values are valid in working conditions: temperature 25°C at sea level. **IMPORTANT:** Engine power will decrease 3.5% for every 300 meters above sea level and 1% for each 5.6°C above 25°C.



2 Water tank

Polyethylene tanks make the entire skid unit lighter. Vallfirest skid units with a polyethylene tank are designed to concentrate the skid unit load in the area closest to the vehicle cabin, avoiding wheel arches on pickup vehicles and optimizing the available space.

- Made of seamless polyethylene via rotational molding.
- 1 1-1/2" filling spout on the top with couplings (Barcelona, Storz, DSP or others) to fill the tank from a hydrant or exterior pressurized water source.
- 1 configurable 1-1/2" high vent on the top.
- 1 threaded inspection cover with a useful diameter of 200 mm to inspect the tank.
- A water level indicator over connecting ducts.
- A 1" drain to empty the tank.
- Pump return connection to fill the tank by suctioning water from a non-pressurized external water source.

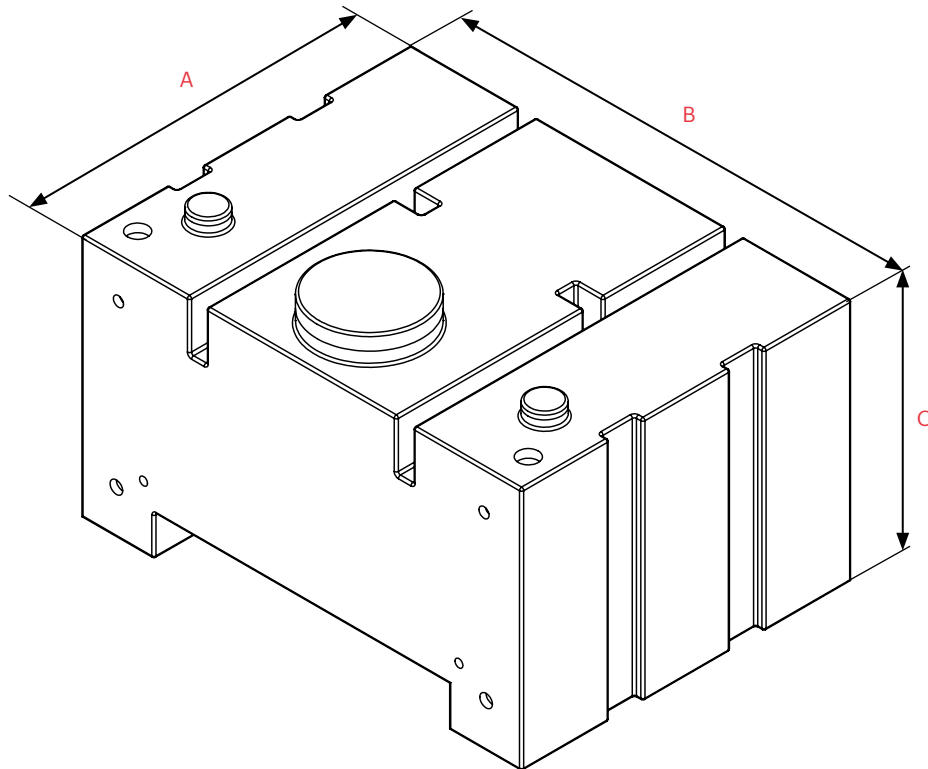

A: Depth
 B: Width
 C: Height

Standard colors	Tank dimensions			
White Red	Tank	A [mm]	B [mm]	C [mm]
	400 RV	790	1050	585

3 Components included

3.1 Control panel

Control panel with LED light switch, pressure gauge, time counter, pressure regulator, filter, valves for suction and water drive, and foam percentage regulation knob.

TECHNICAL DATA

- Baked paint coating



3.2 Winder

Made of anti-corrosive material with a manual starting crank and lock system.

TECHNICAL DATA

- Capacity for 50 m long DN12 hose*



3.3 Foam-forming agent proportioner system

Compact and easy-to-use, foam mixing with a proportional manual selector valve. Creates a stable mix of foam-forming agent in the water. Venturi effect "in line eductor" system which mixes water and foam-forming agent in the drive circuit.



3.4 Suction oversleeve

Clear flexible PVC spiral absorption oversleeve with rigid PVC spiral and smooth inner surface. Includes non-return foot valve and filter. Includes a Storz connector for connection to the Vallfirest skid unit.

TECHNICAL DATA

- Length: 5 m
- Oversleeve diameter: DN25 (1")
- Weight: 2.2 kg (DN25)



3.5 Hose

DN12 (1/2") or DN10 (3/8") rigid hose as per the pump model. Comprised of an inner layer of synthetic rubber reinforced with 1 metal mesh (R1AT) or 2 meshes (R2AT). Features a quick connection system for a multi-purpose water and foam nozzle.

TECHNICAL DATA

Hose type as per the operating pressure:

- SAE 100 R1AT DN12 (1/2"): 160 bar operating pressure, 0.45 kg/m weight
- SAE 100 R2AT DN12 (1/2"): 275 bar operating pressure, 0.65 kg/m weight
- **Ask for other hose lengths**



3.6 Multi-purpose nozzle

High-pressure and high-range nozzle for water and foam. With quick connection system.*

TECHNICAL DATA

- Maximum pressure: 250 bar
- Maximum flow: 45 L/min.
- Concentrated stream >—
- Hollow cone/fog stream >◀
- Foam stream >◀

* Ask about options for 280 bar skid units



3.7 Tank lifting structure

Tank frame enabling the tank to be lifted and transported by means of a pallet jack or forklift.

DATOS TÉCNICOS

- 100*50*2 mm steel tube, 1400 mm long section.
- Durable powdercoated finish.

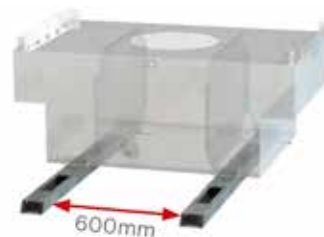

4 Optional accessories

4.1 Nozzles

Water

High-pressure and high-range nozzle. Adjustable angle. Interchangeable ceramic nozzle tip and quick connection system.

TECHNICAL DATA

- Maximum pressure: 220 bar
- Maximum flow: 45 L/min.
- Concentrated stream >—
- Hollow cone/fog stream >◀



Foam

High-pressure and high-range nozzle. Adjustable angle. With quick connection system.*

TECHNICAL DATA

- Maximum pressure: 280 bar
- Maximum flow: 45 L/min.
- Concentrated stream >—
- Hollow cone/fog stream >◀



4.2 100 m Manual winder

Made of anti-corrosive material with a manual starting crank and lock system.

TECHNICAL DATA

- Capacity for 100 m flat 25 hose

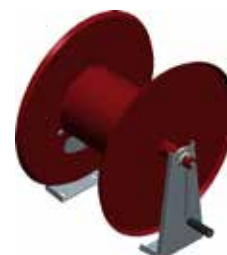

4.3 Electric winder

Made of anti-corrosive material. With an electric rewinder with a 12V motor.

TECHNICAL DATA

- Capacity for 50 DN12 (1/2") hose
- Ask for longer hose lengths..



4.4 Tool carrier structure

Different possibilities; fully customizable. The operability of pickup vehicles is increased with tool carrier structures accompanying the units: manual tools, drip torches, chainsaws, water packs, combat packs.

TECHNICAL DATA

- Features a tool carrier cabinet
- Features an equipment carrier tray with a railing
- Custom made for each vehicle
- Approximate total weight: 80 kg



5 General Dimensions

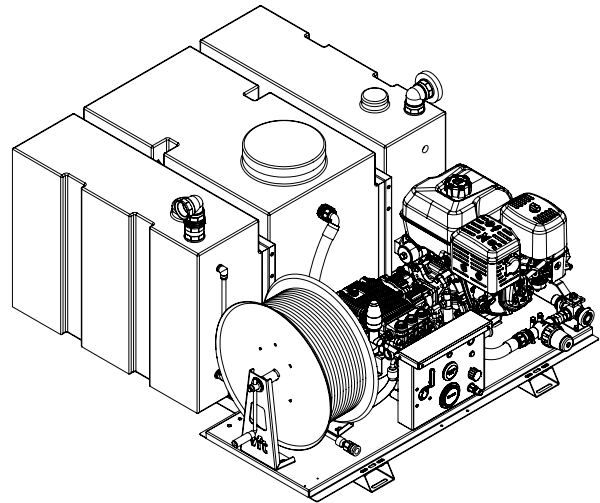
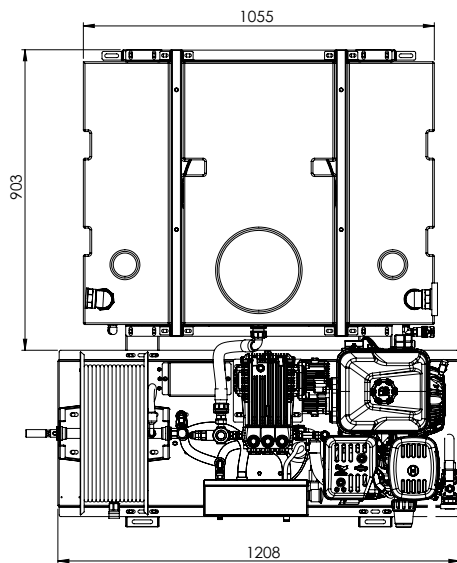
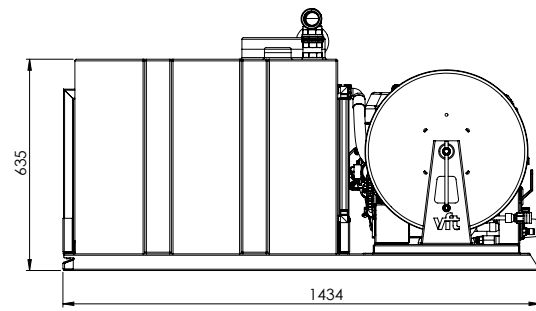
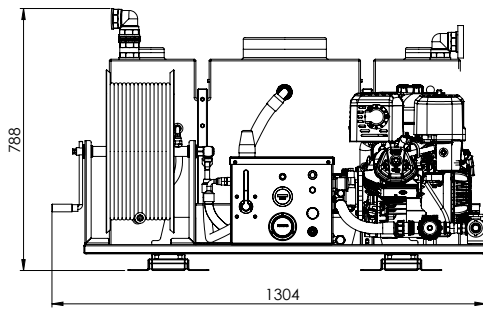

6 Configurations available

Ref. VFT	Tank	Motor	Battery and electric start	Power *	Pump	Max. Pressure **	Max. flow **	Approx dry weight
DVD134V-G63A0	400 RV	B&S XR2100	YES	13.5 HP	XWL 42.10 N	100 bar	42 l/min	
DVD134V-G67A0	400 RV	B&S XR2100	YES	13.5 HP	XW 21.20 N	200 bar	21 l/min	

PV: vertical polyethylene tank.

Gasoline motor.

* The nominal engine power indicated in this document is the net power tested on a production engine for the engine model pursuant to SAE J1940 (Briggs& Stratton) at a specific speed. This value may vary in mass produced motors. The actual output power of the engine installed on the end machine will vary depending on a number of factors such as the applicable engine operating speed, the environmental conditions, maintenance and other variables.

** These values are at direct pump outlet.

*** The power, pressure and flow values are valid in working conditions: temperature 25°C at sea level. **IMPORTANT:** Engine power will decrease 3.5% for every 300 meters above sea level and 1% for each 5.6°C above 25°C.

Any questions? Contact us: clientes@vallfirest.com | T. +34 938 678 779